

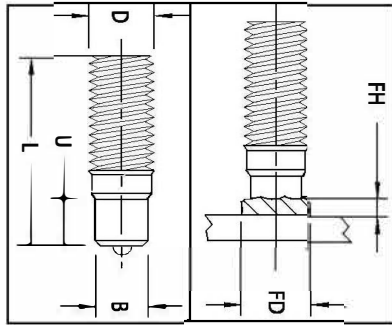

# TRU-FIT PRODUCTS • TRU-WELD

QUALITY WELD STUDS, STUD WELDING EQUIPMENT AND FASTENERS SINCE 1928

Atlanta • Calgary • Chicago • Dallas • Denver • Houston • Las Vegas • Medina • New York City • Salt Lake City • Smithville • Toronto • Vancouver



## THREADED STUD – REDUCED WELD BASE

TYPE T R STUD

TYPE R FERRULE SUPPLIED

D Stud Diameter	L Length (BW)	TRU-WELD Part Number	B Base Diameter	U Base Length	FD Weld Fillet Diameter	FH Weld Fillet Height	Ferrule Part Number
3/8-16	3/4	TR06-012-11	.310	3/8	7/16	7/64	FER06-R
7/16-14	7/8	TR07-014-11	.373	3/8	1/2	1/8	FER07-R
1/2-13	7/8	TR08-014-11	.435	7/16	19/32	9/64	FER08-R
5/8-11	1	TR10-016-11	.500	1/2	11/16	5/32	FER10-R
3/4-10	1-3/16	TR12-019-11	.625	5/8	7/8	3/16	FER12-R

**TR Studs** are used in all types of applications. They can be welded to a flat surface, or to the inside or outside of an angle.

**Length:** Length is listed before weld. Stud diameters 1/2" and below will be approx. 1/8" shorter after welding. 5/8" – 3/4" will be approx. 3/16" shorter after welding.

TRU-WELD TR Studs can be made in any length above the standard minimum.

**Material:** Low carbon steel, ASTM A29 / A108, 1010-1020. TR Studs are also available in weldable stainless steel. Type 302 is the most commonly used. Other grades of stainless steel (except Type 303) are available when required

### Mechanical Property Requirements

Tensile Strength	61,000 psi min.
Yield Strength	49,000 psi min.
Elongation (% in 2 in.)	17% min.
Elongation (% in 5x dia.)	14% min.
Reduction of Area	50% min.

DIAMETER	CHUCK PART #	Light Duty Standard		Light Duty Split		Standard Combination
		FOOT PART #	GRIP PART #	FOOT PART #	GRIP PART #	FOOT AND GRIP #
3/8	CN-037	B-1N	GN-037	B-1C	GC-037	QN-037
7/16	CN-043	B-1N	GN-043	B-1C	GC-043	QN-044
1/2	CN-050	B-1N	GN-050	B-1C	GC-050	QN-050
5/8	CN-062	B-2N	GN-062	B-2C	GC-062	QN-062
3/4	CN-075	B-2N	GN-075	B-2C	GC-075	QN-075