



# TRU-FIT PRODUCTS • TRU-WELD

QUALITY WELD STUDS, STUD WELDING EQUIPMENT AND FASTENERS SINCE 1928

Atlanta • Calgary • Chicago • Dallas • Denver • Houston • Las Vegas • Medina • New York City • Salt Lake City • Smithville • Toronto • Vancouver

## NO THREAD STUD – FULL WELD BASE

TYPE N T STUD

TYPE F FERRULE SUPPLIED

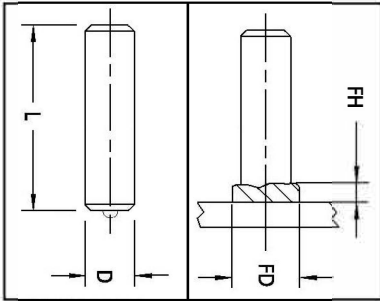

D Stud Diameter	L Length (BW)	TRU-WELD Part Number	FD Weld Fillet Diameter	FH Weld Fillet Height	Ferrule Part Number
1/4	7/8	NT04-014-11	23/64	7/64	FER04-F
5/16	7/8	NT05-014-11	7/16	7/64	FER05-F
3/8	7/8	NT06-014-11	1/2	1/8	FER06-F
7/16	1	NT07-016-11	19/32	9/64	FER07-F
1/2	1	NT08-016-11	11/16	5/32	FER08-F
5/8	1-5/16	NT10-021-11	7/8	3/16	FER10-F
3/4	1-5/16	NT12-021-11	1-1/16	1/4	FER12-F
7/8	1-9/16	NT14-025-11	1-1/8	5/16	FER14-F
1	1-7/8	NT16-030-11	1-3/8	3/8	FER16-F

**NT Studs** are used in all types of applications. They can be welded to a flat surface, or to the inside or outside of an angle.

**Length:** Length is listed before weld. Stud diameters 1/2" and below will be approx. 1/8" shorter after welding. 5/8"- 7/8" will be approx. 3/16" shorter after welding. 1" and above will be 1/4" shorter after weld. TRU-WELD NT Studs can be made in any length above the standard minimum.

**Material:** Low carbon steel, ASTM A29 / A108, 1010-1020. NT Studs are also available in weldable stainless steel.

Mechanical Property Requirements	
Tensile Strength	61,000 psi min.
Yield Strength	49,000 psi min.
Elongation (% in 2 in.)	17% min.
Elongation (% in 5x dia.)	14% min.
Reduction of Area	50% min.

DIAMETER	CHUCK PART #	Light Duty Standard		Light Duty Split		Standard Combination FOOT AND GRIP #
		FOOT PART #	GRIP PART #	FOOT PART #	GRIP PART #	
1/4	CN-025	B-1N	GN-025	B-1C	GC-025	QM-025
5/16	CN-031	B-1N	GN-031	B-1C	GC-031	QM-031
3/8	CN-037	B-1N	GN-050	B-1C	GC-050	QM-050
7/16	CN-043	B-1N	GN-043	B-1C	GC-043	QM-043
1/2	CN-050	B-2N	GN-062	B-2C	GC-062	QM-062
5/8	CN-062	B-2N	GN-075	B-2C	GC-075	QM-075
3/4	CN-075	B-2N	GN-075	B-2C	GC-075	QM-075
7/8	CN-087	B-3N	GN-087	B-3C	GC-087	QM-087
1	CN-100	B-3N	GN-100	B-3C	GC-100	QM-100