

TRU-WELD STUD WELDING

Punching Shear Resistor (PSR) Studs

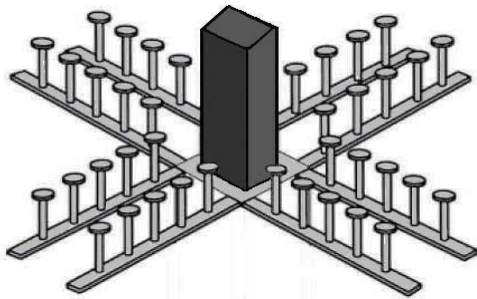

Typical PSR Stud Layout

**TRU-WELD offers
the TRU-TRACE Advantage!**

- TRU-WELD PSR Studs have heat codes stamped on the head that allow traceability to the specific Mill Certification of the stud.
- This expands TRU-WELD's Quality Control Program to trace all PSR Studs up to the point they are poured in concrete!

Punching Shear Resistor (PSR) Application;

Tru-Weld punching shear resistor (PSR) studs are large-headed shear connectors that are welded to flat steel bars (creating stud rails) and used for shear reinforcement in flat concrete slabs to replace stirrups and column capitals to resist the punching shear stress in the slabs.

Studs of a predetermined length and diameter, according to design specifications in compliance with IBC and UBC Structural Steel Welding Standards, are used to extend the column perimeter into the floor or foundation slab. This reduces the amount of reinforcing bar required in an area and column congestion resulting in easier and faster installation, as well as lower cost.

Using these PSR stud rails, you increase the punching shear capacity at the base of the concrete columns, resulting in a significant reduction in slab thickness. This creates a substantial savings in labor and material costs.

Contact a Tru-Weld Sales Rep for ordering details!

1-800-321-5588

PSR Stud Specifications

Stud Diameter	Head Diameter	Head Thickness
3/8" (9.5mm)	1.19" (30.1mm)	0.26" (5.3mm)
1/2" (12.7mm)	1.58" (40.2mm)	0.33" (7.1mm)
5/8" (15.9mm)	1.98" (50.2mm)	0.40" (8.9mm)
3/4" (19.1mm)	2.37" (60.2mm)	0.47" (10.7mm)

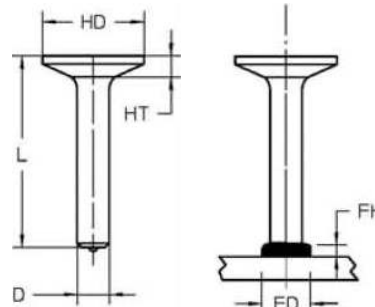

Material ;
ASTM A108 / A29
Grade 1010-1020

Properties;
Yield - 51,000 PSI
Tensile - 65,000 PSI
Elongation - 20% Min.
Reduction Of Area - 50% Min.

TRU-WELD Studs comply with the requirements of AWS D1.1- 2008 Structural Welding Code. (ICC-ES# - ESR-2822)

Benefits of Using PSR Stud Rails;

1. Eliminating the need for column capitals and stirrups
2. Reduction of setup and installation time.
3. Reduction of congestion around column/slab connections.
4. Distribution of force over a greater critical area.
5. Providing higher tensile strength and more ductile performance of the concrete slab.

PSR Stud Column Layout

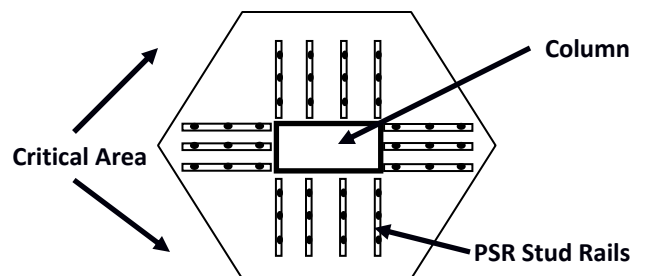

460 Lake Road
Medina, Ohio 44256
<http://truweldstudwelding.com>
Truweld@tfpcorp.com

(800) 321-5588 Toll Free
(330) 725-7741 Phone
(330) 725-0161 Fax

MADE IN AMERICA

