



TRU-WELD Stud Welding

COLLAR STUD

TYPE CS STUD

THREADED TO COLLAR- PITCH DIAMETER WELD BASE

TYPE C FERRULE SUPPLIED

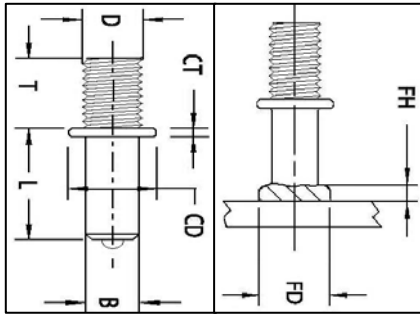

D Thread Diameter	T Thread Length	TRU-WELD Part Number	B Base Diameter	T Stud Length	FD Weld Fillet Diameter	FH Weld Fillet Height	Ferrule Part Number
1/4-20	1/4	CS03-008-11-04-004	.215	1/2	23/64	7/64	FER04-C
5/16-18	3/8	CS04-008-11-05-006	.275	1/2	7/16	7/64	FER05-C
3/8-16	3/8	CS05-008-11-06-006	.330	1/2	1/2	1/8	FER06-C
1/2-13	3/8	CS07-009-11-08-006	.448	9/16	11/16	5/32	FER08-C

Collar Studs are used in all types of applications. They can be welded to a flat surface, or on the inside or outside of an angle.

Length: Length is listed before weld. Stud diameters 1/2" and below will be approx. 1/8" shorter after welding.

TRU-WELD Collar Studs can be made in any length above the standard minimum.

Material: Low carbon steel, ASTM A29, 1010-1020. Collar Studs are also available in weldable stainless steel. Type 302 is the most commonly used. Other grades of stainless steel (except Type 303) are available when required.

Mechanical Property Requirements	
Tensile Strength	55,000 psi min.
Yield Strength	50,000 psi min.
Elongation (% in 2 in.)	17% min.
Elongation (% in 5x dia.)	14% min.
Reduction of Area	50% min.

THREAD DIAMETER	CHUCK PART #	Light Duty Standard		Light Duty Split		Standard Combination
		FOOT PART #	GRIP PART #	FOOT PART #	GRIP PART #	FOOT AND GRIP #
1/4"	CN-031	B-2N	GN-062	B-2C	GC-062	QM-062
5/16"	CN-037	B-2N	GN-062	B-2C	GC-062	QM-062
3/8"	CN-043	B-2N	GN-062	B-2C	GC-062	QM-062
1/2"	CN-050	B-2N	GN-075	B-2C	GC-075	QM-075